

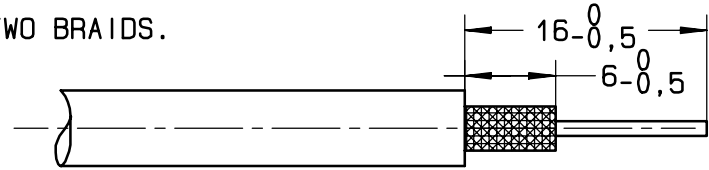

STEP 1- WIRE STRIPPING:  
NOTA: FOR FILECA 1703/93 CABLE,  
SUPPRESS THE HI HIMUNITY RIBBON BETWEEN THE TWO BRAIDS.

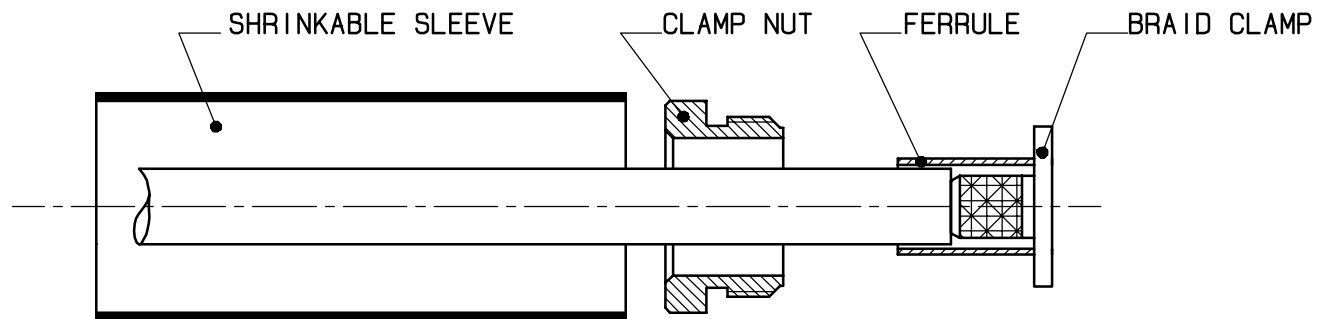

STEP 2- SLIDE THE SHRINKABLE SLEEVE, THE CLAMP NUT AND THE FERRULE ON THE CABLE.  
SLIDE THE BRAID CLAMP OVER THE DIELECTRIC, AND UNDER THE BRAIDS.  
PUT THE FERRULE ON THE BRAIDS AND PUSH IT AGAINST THE BRAID CLAMP.  
CRIMP THE FERRULE WITH M22520/5-01(RADIALL 282 293) CRIMPING TOOL AND  
M22520/5-05(RADIALL 282 246) HEX A DIE.



STEP 3- THEN CUT THE DIELECTRIC FLUSH WITH BRAID CLAMP.

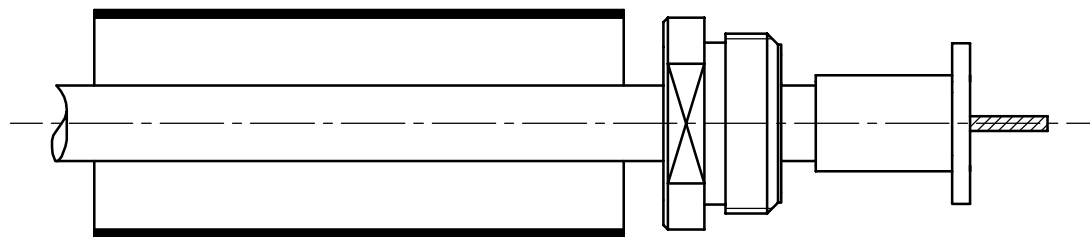

STEP 4- SLIDE THE WASHER ON THE CENTER CONDUCTOR AND PUSH IT AGAINST THE BRAID CLAMP.  
SLIDE THE INNER CONTACT ON THE CENTER CONDUCTOR AGAINST THE WASHER.  
CRIMPING THE INNER CONTACT WITH M22520/1-01(RADIALL 282 291) CRIMPING TOOL  
SELECTOR 7, POSITIONNER M22520/1-13(RADIALL 282 997) RED TURRET.

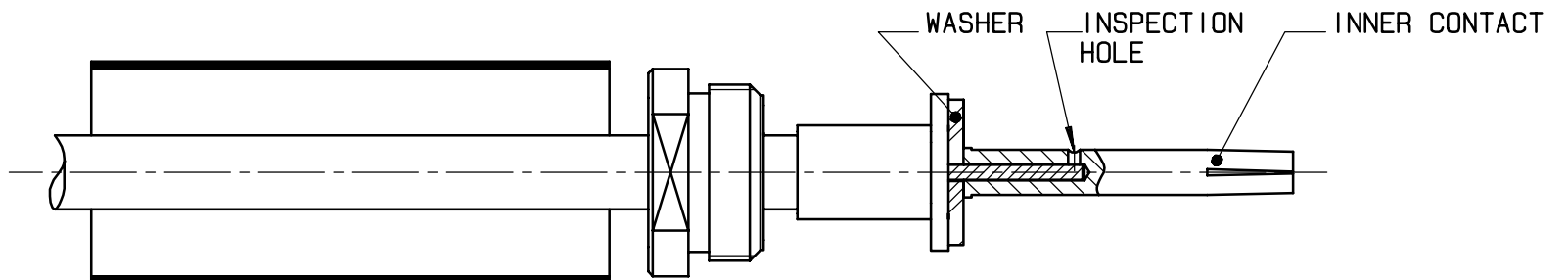

STEP 5- SLIDE CENTER CONTACT SUB-ASSEMBLY INTO THE OUTER BODY TIGHTEN THE  
CLAMP NUT: MAX TORQUE: 370N.Cm  
PUT THE SHRINKABLE SLEEVE ON THE CLAMP NUT AND THE OUTER CONTACT  
AND SHRINK IT.

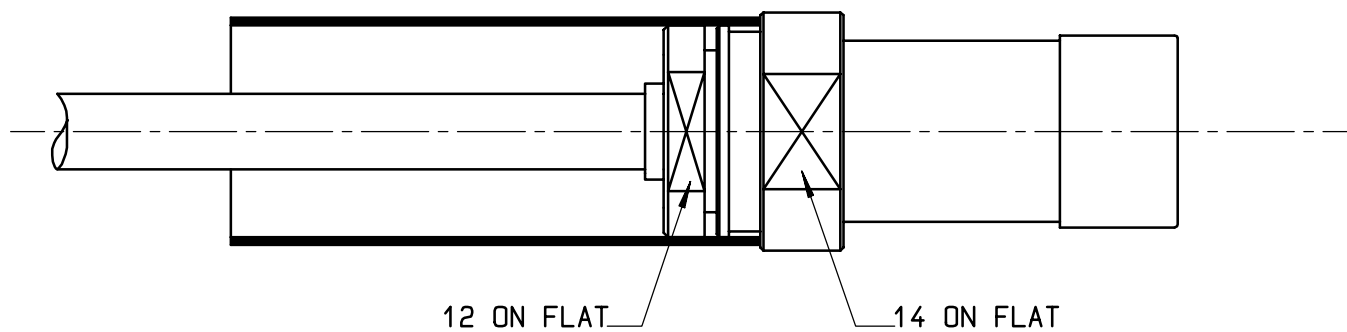

This information is given as an indication. In the continual goal to improve our products, we reserve the right to make any modifications judged necessary.

4112-9610

CREATION	.	.	.	.
PEN: /	.	.	.	.
NOM: FALETTI	.	.	.	.
DATE: 13-12-84	.	.	.	.
APPR.: .	05/22/00	DRAWN IN US VERSION	HASCOET	.
	Issue	Revisions	Name	Approved

**RADIALL**<sup>®</sup>

101, rue Philibert Hoffmann Z.I. Ouest  
93116 ROSNY/BOIS Cedex (France)  
Tl.: 01 49 35 35 35  
Fax.: 01 48 54 63 63  
Tlax: RADIA 235220